



## HEAVY DUTY GREASE PUMPS 70:1 450 SERIES PUMP

OPERATION, INSTALLATION, MAINTENANCE  
AND REPAIR GUIDE

PART NO.:

L791450-005 - GREASE PUMP, HEAVY DUTY, 400 LB

L791450-006 - GREASE PUMP, HEAVY DUTY, 120 LB

L791450-007 - GREASE PUMP, HEAVY DUTY, BULK TOTE

COMPRESSED AIR OPERATED PISTON-TYPE RECIPROCATING PUMP. THIS HIGH FLOW CAPACITY PUMP IS COMPATIBLE WITH MINERAL AND SYNTHETIC GREASE AND SUITABLE FOR LARGE INSTALLATIONS WITH LONG LENGTHS OF PIPING SUPPLYING SEVERAL OUTLETS SIMULTANEOUSLY. THIS PUMP IS MOUNTED DIRECTLY ON 120 LB (50 KG) AND 400 LB (185 KG) DRUMS. A SHORTER PUMP IS ALSO AVAILABLE (L791450-007) WITH A BUNDLED MALE 3" CAMLOCK, SUITABLE FOR HORIZONTAL DIRECT ASSEMBLY TO BULK CONTAINERS.



READ BEFORE USE



WARNING



**WARNING:** READ ALL INSTRUCTION MANUALS, TAGS, AND LABELS BEFORE OPERATING THE EQUIPMENT. THIS EQUIPMENT IS FOR PROFESSIONAL USE ONLY.



**DANGER:** NOT FOR USE WITH FLUIDS THAT HAVE A FLASH POINT BELOW 100 °F (38 °C). EXAMPLES: GASOLINE, ALCOHOL. SPARKING COULD RESULT IN AN EXPLOSION WHICH COULD RESULT IN DEATH.



**WARNING:** IN THE PRESENCE OF EXPLOSIVE VAPORS, TAKE ACTION TO PREVENT STATIC SPARKING. FAILURE TO GROUND THE PUMP, PIPING, VALVES, CONTAINERS OR OTHER MISCELLANEOUS EQUIPMENT CAN RESULT IN FIRE OR EXPLOSION. A GROUNDING BOLT IS PROVIDED ON THE PUMP.



**WARNING: THIS PUMP CONTAINS ZINC PARTS.**

DO NOT USE 1-1-1 TRICHLOROETHANE, METHYLENE CHLORIDE OR OTHER HALOGENATED HYDROCARBON SOLVENTS OR FLUIDS CONTAINING SUCH SOLVENTS IN THIS PUMP. USE OF THESE SOLVENTS/FLUIDS MAY RESULT IN A VIOLENT CHEMICAL REACTION, CAUSING SERIOUS BODILY INJURY, PROPERTY DAMAGE OR DEATH. ALL FLUIDS USED IN THIS PUMP MUST BE CHEMICALLY COMPATIBLE WITH THE WETTED PARTS MATERIALS. CONSULT YOUR CHEMICAL SUPPLIER TO ENSURE COMPATIBILITY.

THE PUMP GENERATES HIGH OR VERY HIGH PRESSURES. DO NOT EXCEED THE MAXIMUM AIR INLET PRESSURE OF 100 PSI (7 BAR).

A DIRECT HIT AGAINST THE HUMAN BODY MAY RESULT IN AN INJURY.

THIS UNIT MAY HAVE STORED PRESSURE, RELEASE ALL PRESSURE AND DISCONNECT FROM ANY FLUID SYSTEMS BEFORE SERVICING. TO ENSURE SAFE OPERATION OF THIS UNIT, ALL SERVICE WORK SHOULD BE PERFORMED BY QUALIFIED PERSONNEL ONLY.

WHEN NOT IN USE, BE SURE TO SHUT OFF THE AIR SUPPLY TO AVOID ACCIDENTS.

DO NOT ALTER OR MODIFY THIS EQUIPMENT. ANY UNAUTHORIZED TAMPERING WITH THIS EQUIPMENT, IMPROPER USE, POOR MAINTENANCE OR REMOVAL OF IDENTIFICATION LABELS MAY INVALIDATE THE WARRANTY.

ALL FITTINGS IN THE SYSTEM CONNECTED TO THE OUTLET OF THE PUMP SHOULD BE SUITABLE FOR THE MAXIMUM POSSIBLE PRESSURE GENERATED BY THE PUMP/AIR MOTOR. IF THE SYSTEMS CANNOT BE DESIGNED TO TAKE THE MAXIMUM PRESSURE PRODUCED BY THE PUMP, SAFETY VALVES OR DIVERTER VALVES SHOULD BE FITTED.

## PUMP INSTALLATION

IT IS RECOMMENDED TO INSTALL THIS PUMP ON A DRUM USING A REINFORCED COVER DUE TO WEIGHT CONSIDERATIONS:

**A.** MOUNTING WITH REINFORCED COVER L794420-013 FOR 400 LB (185 KG) DRUM AND L794420-014 FOR 120 IB (50 KG) DRUM. INSERT THE PUMP THROUGH THE COVER AND FASTEN IT WITH THE ENCLOSED SCREWS. INSERT THE PUMP THROUGH THE BUNG OPENING AND FASTEN THE COVER ONTO THE DRUM FIRMLY (SEE FIGURE 2).

**B.** HORIZONTAL MOUNTING TO A BULK CONTAINER (L791450-007 PUMPS). THESE PUMPS HAVE THE MALE PART OF A 3" CAMLOCK WHICH WOULD CONNECT TO THE FEMALE PART INSTALLED IN THE CONTAINER (FIG. 3).

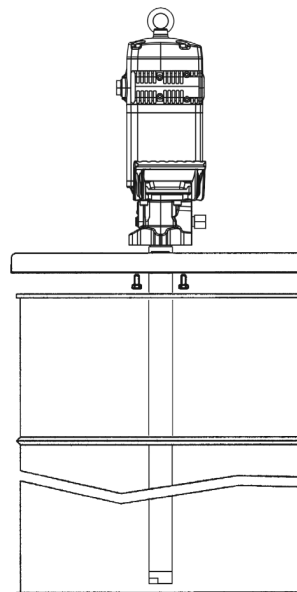

**Fig. 2**

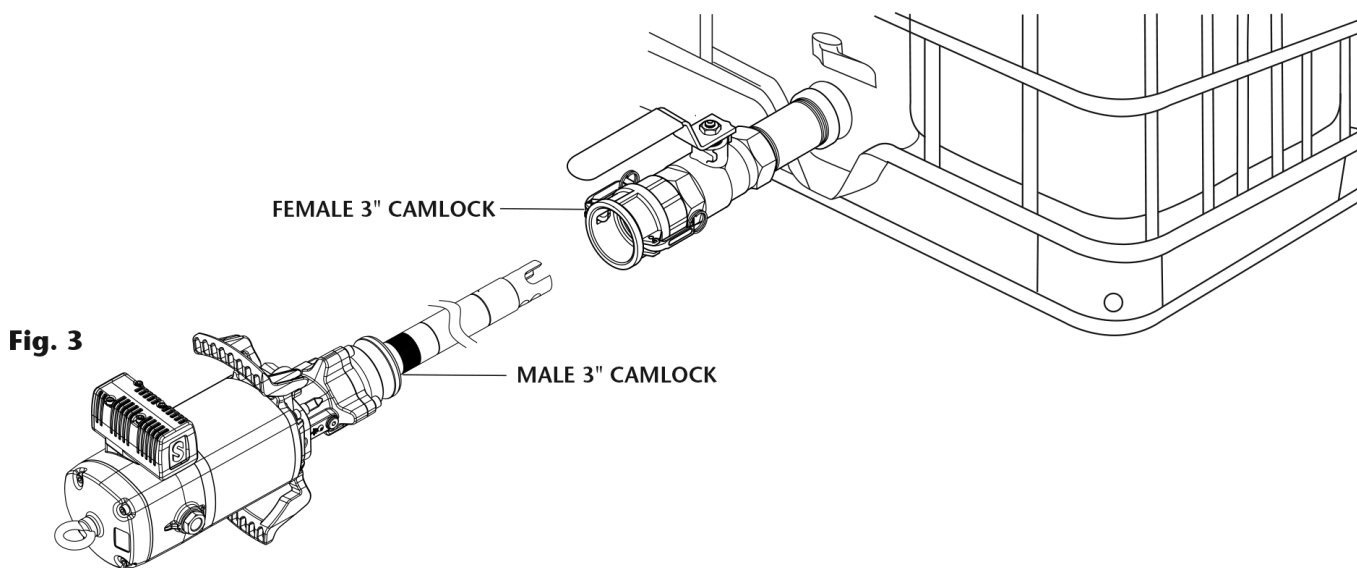

**Fig. 3**

## TYPICAL PUMP INSTALLATION

FIGURE 4 IS A TYPICAL INSTALLATION SHOWN WITH ALL THE RECOMMENDED ACCESSORIES FOR THE PUMP TO OPERATE CORRECTLY.

**NOTE:** THE COMPRESSED AIR SUPPLY MUST BE SET BETWEEN 29 AND 100 PSI (2 AND 7 BAR), 90 PSI (6 BAR) BEING THE RECOMMENDED PRESSURE. AN AIR CLOSING VALVE MUST BE INSTALLED, IN ORDER TO BE ABLE TO CLOSE THE COMPRESSED AIR LINE AT THE END OF THE DAY (IF THE AIR INLET NOT IS CLOSED AND THERE IS A LEAKAGE IN SOME POINT OF THE GREASE OUTLET CIRCUIT, THE PUMP WILL START AUTOMATICALLY, EMPTYING THE CONTAINER).

(CONTINUED ON NEXT PAGE)

TYPICAL PUMP INSTALLATION (CONTINUED)

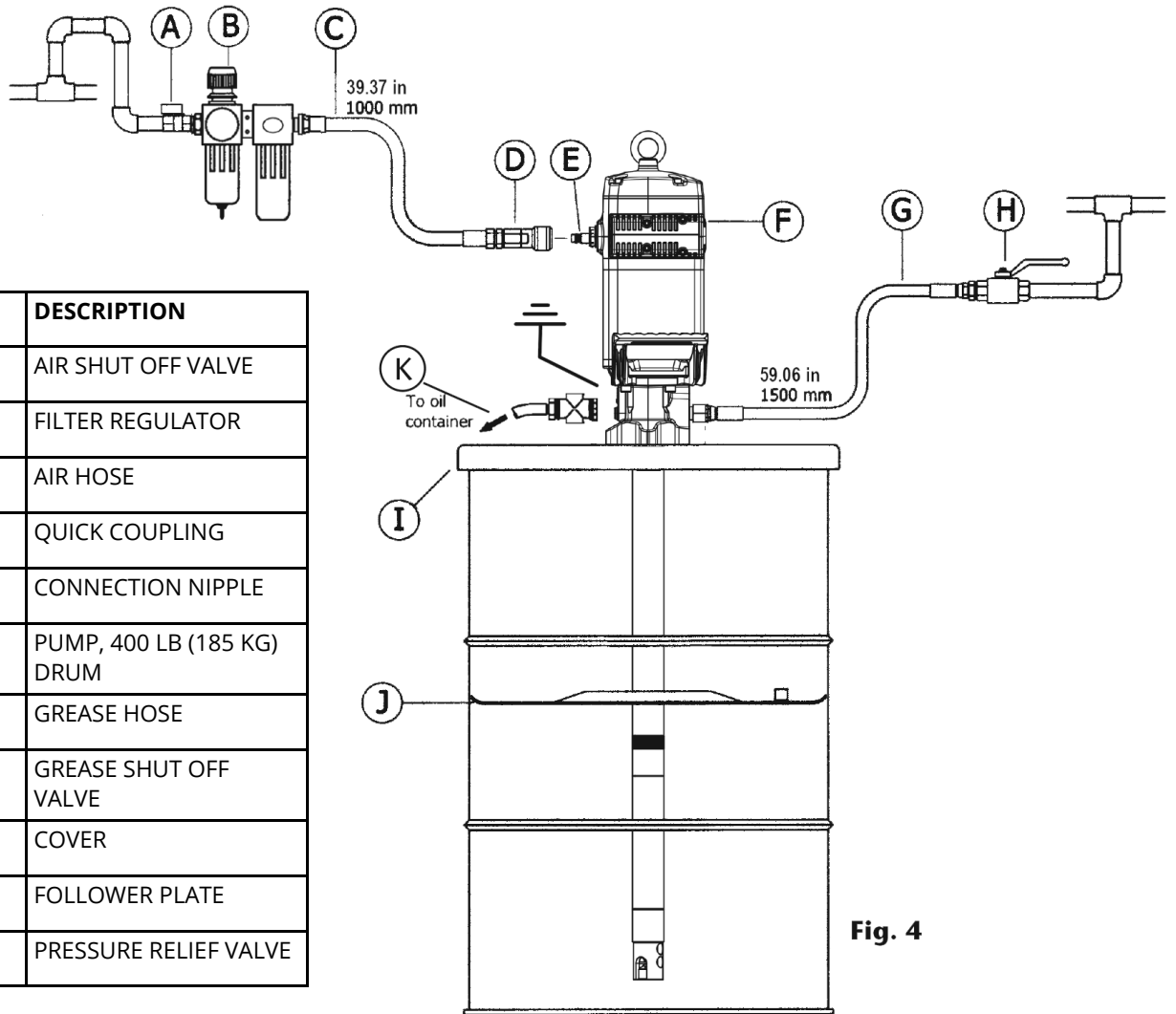

POSITION	DESCRIPTION
A	AIR SHUT OFF VALVE
B	FILTER REGULATOR
C	AIR HOSE
D	QUICK COUPLING
E	CONNECTION NIPPLE
F	PUMP, 400 LB (185 KG) DRUM
G	GREASE HOSE
H	GREASE SHUT OFF VALVE
I	COVER
J	FOLLOWER PLATE
K	PRESSURE RELIEF VALVE

Fig. 4

OPERATION

THIS PUMP IS SELF-PRIMING. TO PRIME IT THE FIRST TIME, IT IS CONVENIENT TO CONNECT THE AIR SUPPLY TO THE PUMP WHILE KEEPING THE OUTLET GUN OPENED, AND INCREASE THE AIR PRESSURE SLOWLY FROM 0 PSI (0 BAR) TO THE DESIRED PRESSURE BY USING A PRESSURE REGULATOR. ONCE GREASE STARTS FLOWING THROUGH ALL THE OUTLETS, THE PUMP IS PRIMED. THE PUMP STARTS TO PUMP WHEN AN OUTLET VALVE IS OPENED, FOR EXAMPLE A GREASE CONTROL GUN.

**NOTE:** IT IS IMPORTANT THAT THE FOOT VALVE DOES NOT COME IN CONTACT WITH DIRTY AREAS, SUCH AS A WORKSHOP FLOOR, BECAUSE IT MAY BECOME CONTAMINATED WITH DIRT OR OTHER PARTICLES THAT CAN DAMAGE THE SEALS.

## TROUBLESHOOTING

SYMPTOMS	POSSIBLE REASONS	SOLUTIONS
THE PUMP IS NOT WORKING OR THERE IS NO GREASE DELIVERY.	NO SUITABLE AIR SUPPLY PRESSURE.	INCREASE THE AIR SUPPLY PRESSURE.
	SOME OUTLET CIRCUIT ELEMENT IS CLOGGED OR CLOSED.	CLEAN OR OPEN THE OUTLET CIRCUIT.
	THERE IS AN AIR POCKET IN THE GREASE INLET AREA.	STIR AND REPACK THE GREASE.
THE PUMP BEGINS TO OPERATE VERY FAST.	THE DRUM IS EMPTY OR THE GREASE LEVEL IS BENEATH THE SUCTION TUBE INLET.	REPLACE THE DRUM OR INSERT THE SUCTION TUBE UNTIL THE INLET REACHES THE GREASE LEVEL.
THE PUMP KEEPS ON OPERATING ALTHOUGH THE GREASE OUTLET IS CLOSED.	THERE IS A GREASE LEAKAGE AT SOME POINT IN THE CIRCUIT.	VERIFY AND TIGHTEN OR REPAIR.
	CONTAMINATION IN THE UPPER VALVE.	DISASSEMBLE AND CLEAN. REPLACE IF DAMAGED.
	CONTAMINATION IN THE FOOT VALVE.	DISASSEMBLE AND CLEAN. REPLACE IF DAMAGED.
GREASE LEAKAGE THROUGH THE AIR OUTLET MUFFLER OR THE LEAKAGE WARNING HOLE ON THE PUMP BODY (69).	GREASE HAS PASSED OVER TO THE AIR MOTOR CAUSED BY SCRATCHED PISTON ROD (49) OR WORN OR DAMAGED SEALS (54, 57).	VERIFY THE PISTON ROD (49) AND REPLACE DAMAGED / WORN PARTS.
AIR LEAKAGE THROUGH THE AIR OUTLET MUFFLER (25).	DAMAGED OR WORN PISTON O-RING (44).	REPLACE O-RING (44).
	THE AIR SEAL (8) OF THE INVERTER ASSEMBLY IS DAMAGED OR WORN.	REPLACE THE AIR SEAL (8).
	DAMAGED OR WORN SPOOL SEALS.	REPLACE THE SEALS (18) AND (20).
GREASE OUTPUT TOO LOW OR DIMINISHES OVER TIME.	CONTAMINATION IN THE FOOT VALVE.	REMOVE AND CLEAN. REPLACE IF DAMAGED.
	CONTAMINATION IN THE UPPER VALVE.	REMOVE AND CLEAN. REPLACE IF DAMAGED.
	THE EXHAUST MUFFLER IS CLOGGED BY COMPRESSED AIR DIRT OR LUBRICANT.	REPLACE THE MUFFLER FELT.

## REPAIR AND CLEANING PROCEDURE

**WARNING:** BEFORE STARTING ANY KIND OF MAINTENANCE OR REPAIR, DISCONNECT THE COMPRESSED AIR SUPPLY AND OPEN THE VALVE TO RELIEVE THE GREASE PRESSURE.

### SEPARATE THE AIR MOTOR FROM THE PUMP

1. FIX THE PUMP IN A VISE IN HORIZONTAL POSITION (FIG. 5). GENTLY TAP THE UPPER TUBE WITH A HAMMER (73) CLOSE TO THE BODY (69) IN ORDER TO BREAK THE THREAD LOCKER.
2. UNSCREW THE NUT (94) AND REMOVE THE PRIMER (93).
3. THREADED (1/2") BAR, ROD OR ANY KIND OF STRONG TUBE IN THE FLUID OUTLET AND USE IT AS A LEVER TO UNSCREW THE AIR MOTOR.
4. ONCE UNSCREWED, PULL THE MOTOR AWAY UNTILL THE ELASTIC PIN (70) INTO THE ROD (49) BECOMES VISIBLE. WITH A HAMMER AND A SUITABLE PIN PUNCH, EJECT THE PIN (70). THE MOTOR BECOMES LOOSE.

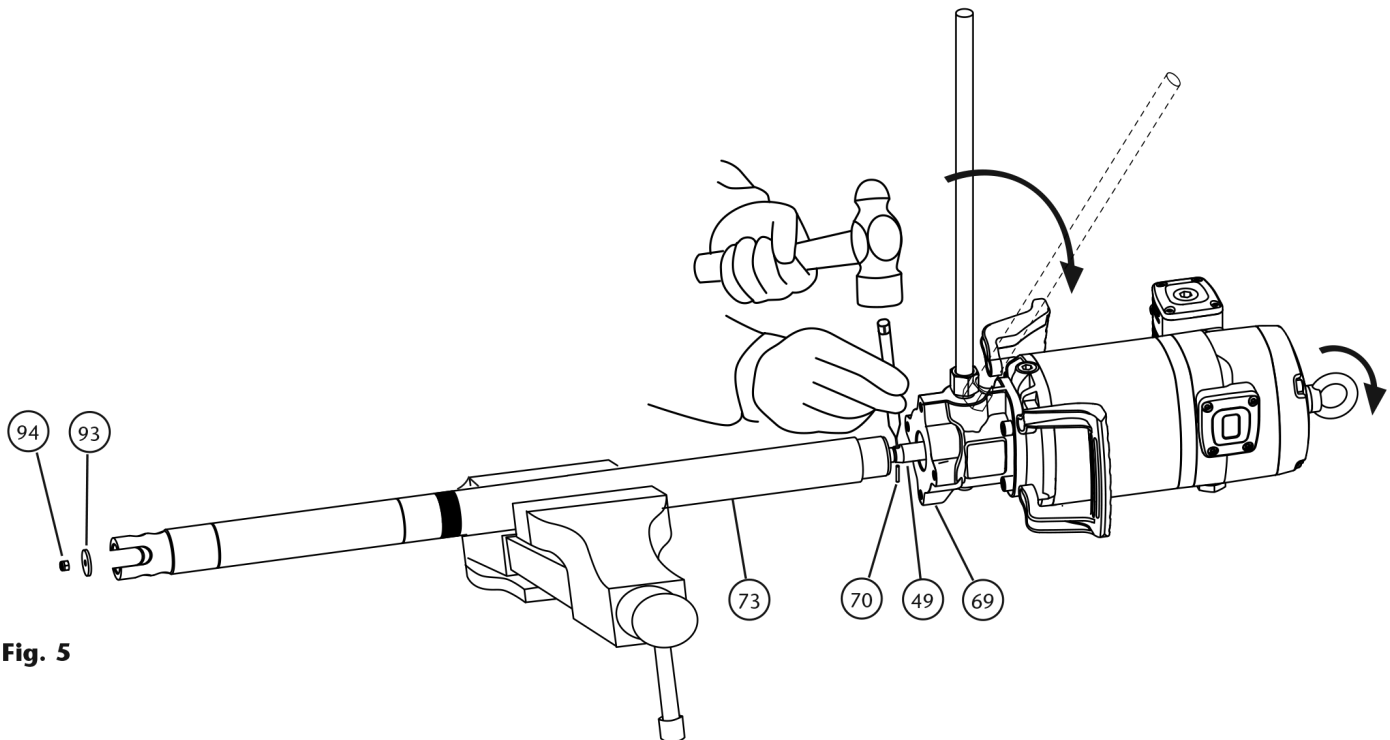

Fig. 5

## REPAIR AND CLEANING PROCEDURE (CONTINUED)

## REPLACING MUFFLER FELTS

1. UNSCREW BOLTS (27).
2. REMOVE EXHAUST ASSEMBLY (25).
3. UNSCREW THE BOLTS (24) AND REMOVE THE CAP (29).
4. REMOVE THE FELT (30).
5. REMOVE THE FELT (31) AND DEFLECTOR (28).
6. REMOVE THE BOTTOM FELT (30) AND REPLACE IT WITH A NEW ONE.
7. PUT BACK THE DEFLECTOR (28).
8. INSERT THE SCREWS (27) AND THEN A NEW FELT (31). IF NOT IN THIS ORDER, IT COULD BE TRICKY TO INSERT THE SCREWS.
9. PUT A NEW FELT (30).
10. PUT BACK THE CAP (29) AND ITS SCREWS (24).
11. ENSURING THE SCREWS (27) STAY INTO THE MUFFLER (25), PUT SAID MUFFLER ON THE MOTOR AND FIX IT WITH SAID SCREWS.

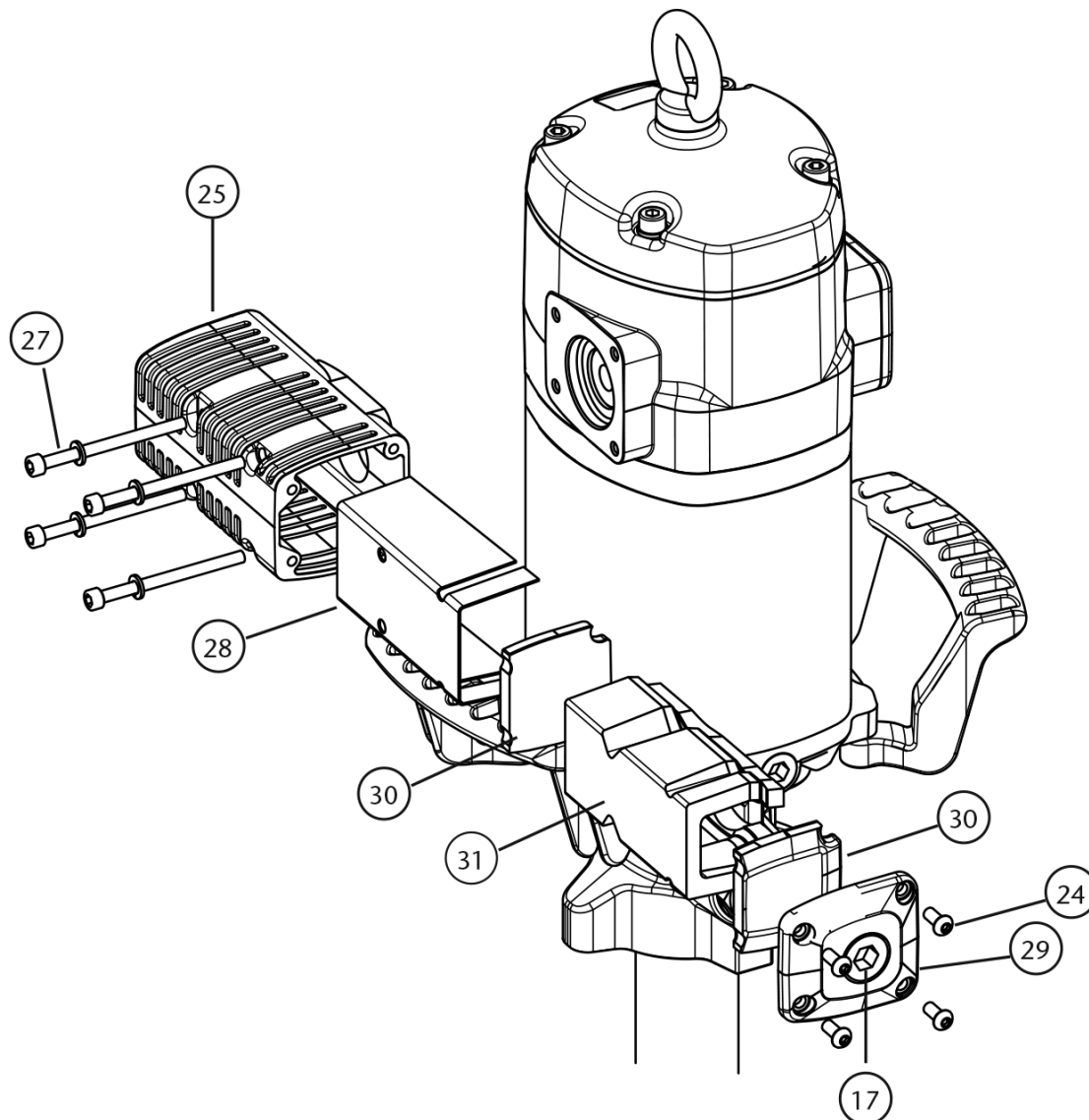

Fig. 7

## REPAIR AND CLEANING PROCEDURE (CONTINUED)

### AIR DISTRIBUTOR

1. UNSCREW THE BOLTS (24) AND REMOVE THE CAP (23).
2. ENSURING THE SCREWS (27) REMAIN INTO THE MUFFLER (25), UNSCREW THEM AND TAKE AWAY THE MUFFLER. TAKE AWAY THE O-RING (16).
3. STRIKE GENTLY WITH A PLASTIC TOOL THROUGH EXHAUST SEAT TO REMOVE THE SPOOL VALVE (19).
4. REPLACE THE WHOLE SPOOL (19) WITH ITS SEALS FACTORY INSTALLED (KIT L79833414).

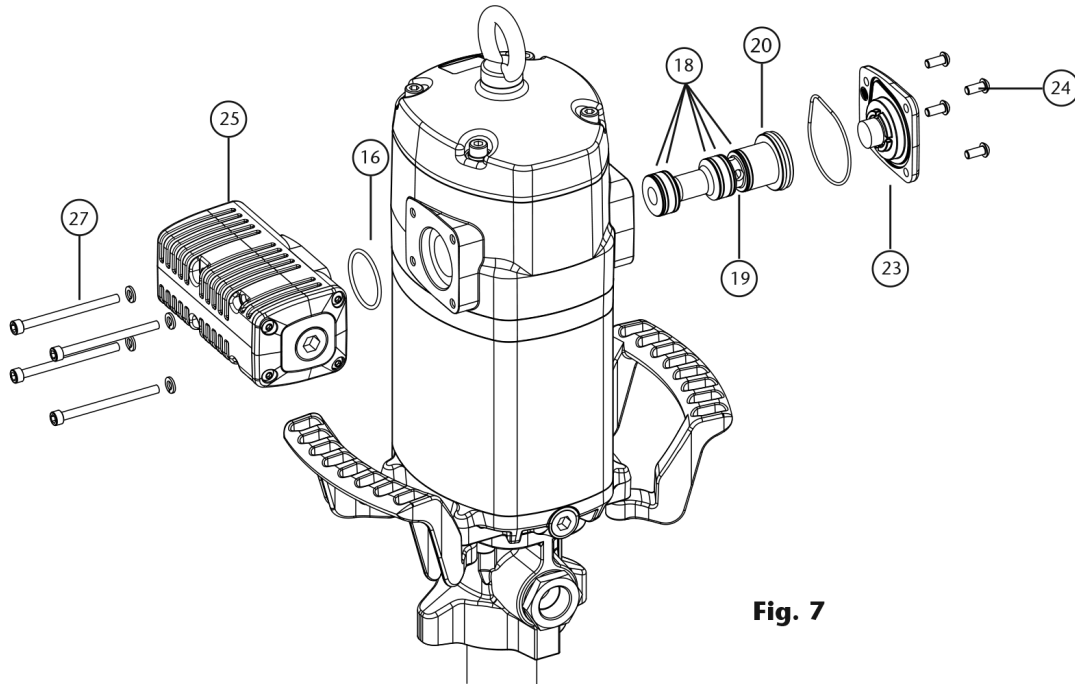

Fig. 7

### AIR DISTRIBUTOR

1. UNSCREW THE BOLTS (2) AND REMOVE THE CAP (3).
  2. UNSCREW THE SENSOR SLEEVE (4).
  3. WITH A MANUAL CLAMP ON THE NUT (5), PULL THE ROD (40) OUTWARDS UNTIL ITS CENTRAL RECESS APPEARS (FIG. 8A). THEN, WITH ANOTHER MANUAL CLAMP, GRAB THE ROD (40) ON THE RECESS TO PREVENT SEALING SURFACE FROM BEING DAMAGED, AND UNSCREW THE NUT (5) (FIG. 8B).
  4. REMOVE O-RING (6) AND RING (7), AND REPLACE THEM WITH NEW ONES LATER DURING REASSEMBLY.
  5. UNSCREW THE BOLTS (55). PULL THE MOTOR BODY (13) OUTWARDS TO FREE IT ALONG WITH BRIDLE (36).
  6. TAKE AWAY THE GASKET (9) AND REPLACE ITS SEALS (8) AND (10).
  7. UNSCREW THE BOLTS (37) AND SEPARATE THE MOTOR (13) FROM THE BRIDLE (36). TAKE AWAY THE WASHER (32) AND REPLACE THE SEAL (8).
  8. TAKE AWAY THE CYLINDER (50) WHILE CAREFULLY HOLDING THE AIR PISTON (45). REPLACE THE PISTON SEAL (44).
  9. REASSEMBLE IN REVERSE ORDER, APPLYING THREAD LOCKER IN SCREWS (37), NUT (5) AND SENSOR SLEEVE (4).
- NOTE:** ALL OF THESE SEALS ARE INCLUDED IN THE KIT L79833412.



## REPAIR AND CLEANING PROCEDURE (CONTINUED)

### AIR MOTOR SEALS

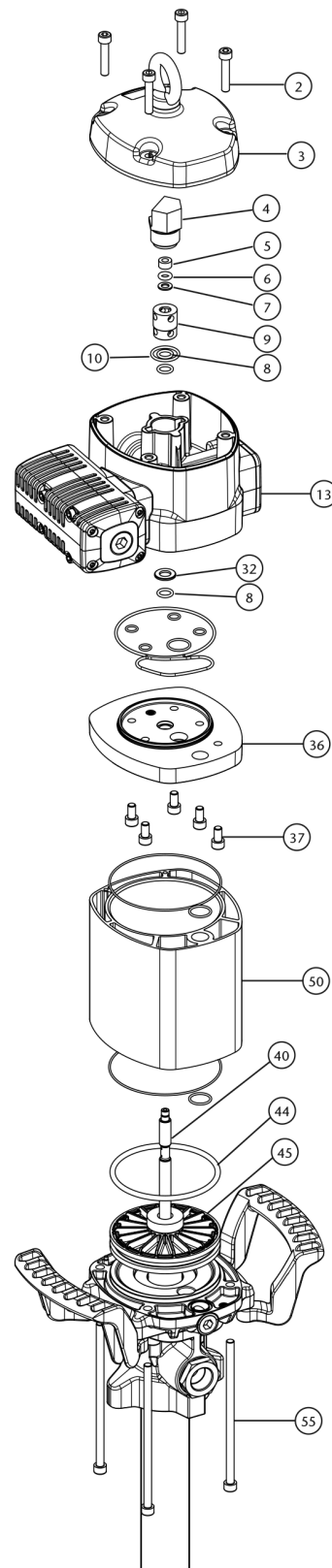
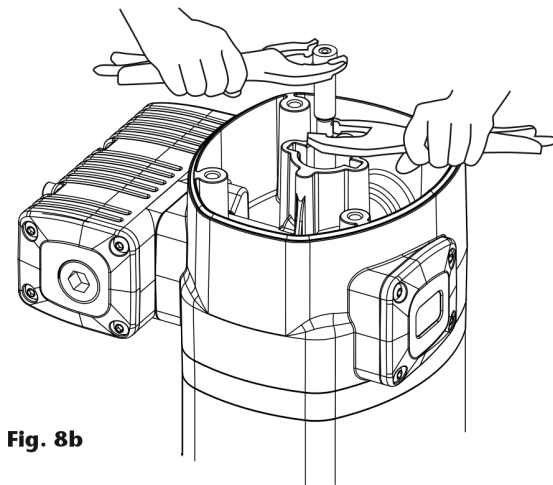
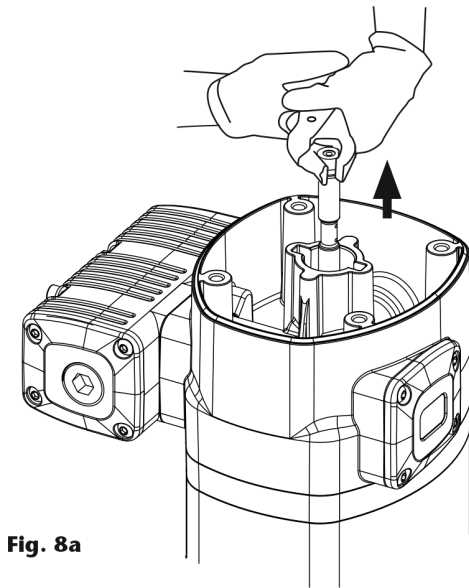

## REPAIR AND CLEANING PROCEDURE (CONTINUED)

### LOWER SEALS KIT

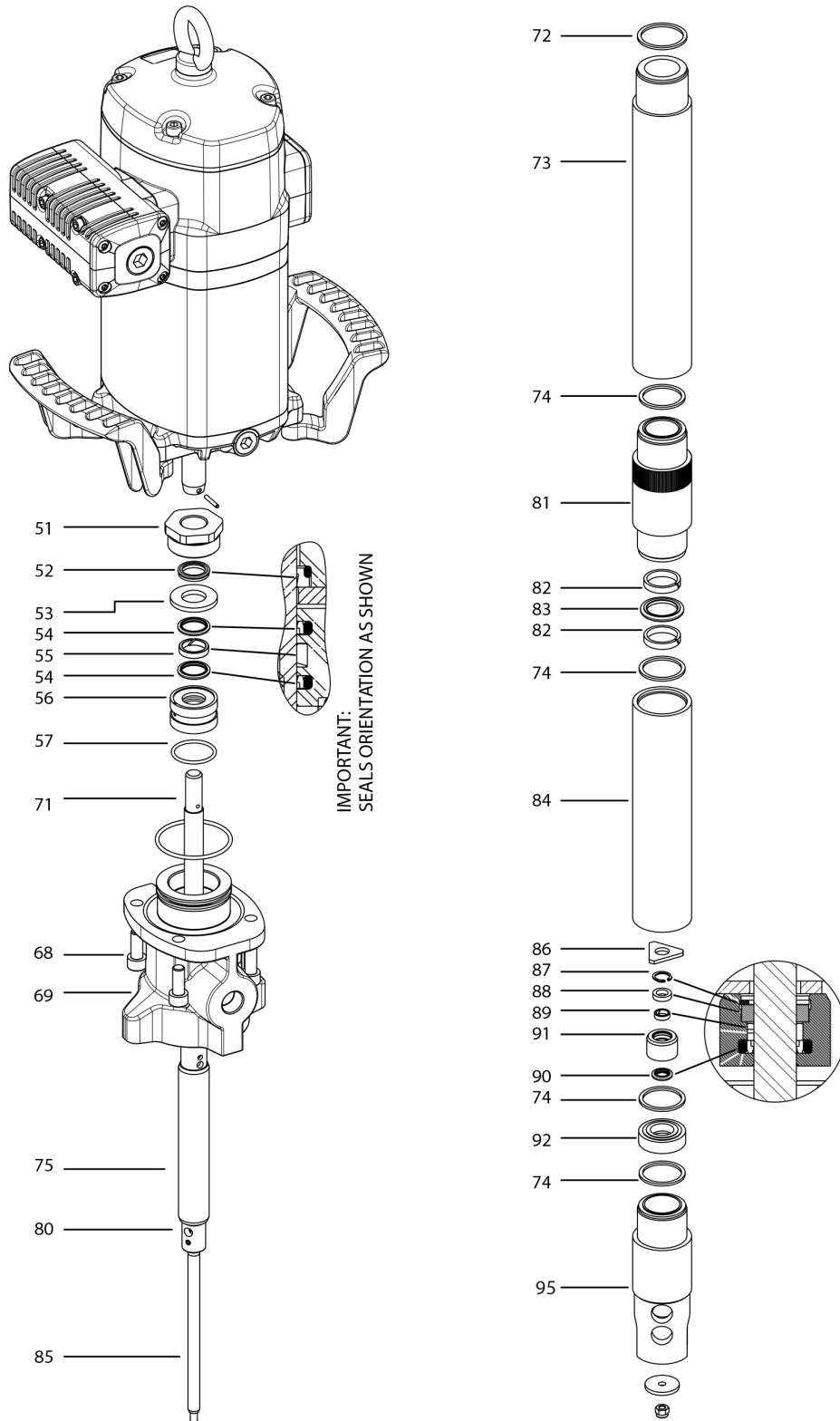

## REPAIR AND CLEANING PROCEDURE (CONTINUED)

### LOWER SEALS KIT

1. TAKE AWAY THE AIR MOTOR FROM THE LOWER END, AS DESCRIBED PREVIOUSLY.
2. UNSCREW THE BOLTS (68) AND REMOVE THE BODY (69).
3. UNSCREW THE SCRAPER NUT (51) AND EXTRACT BOTH THE WASHER (53) AND THE GASKET (56). REPLACE SEALS (52), (54) X 2, (55) AND (57) WITH NEW ONES.
4. TAKE AWAY THE ASSEMBLY CONSISTING OF PARTS (71), (75), (80) AND (85) FROM THE LOWER END.
5. WITH THE TUBE (73) SECURED IN A VISE, UNSCREW THE TUBE (95).
6. EXTRACT THE PARTS 2 X (74), (91) AND (92). TAKE AWAY THE CIRCLIP (87) FROM THE VALVE (91) AND REPLACE PARTS (88), (89) AND (90) WITH NEW ONES.
7. USING THE KNURLED SURFACE, UNSCREW THE PART (81) AND REPLACE THE SEALS 2 X (82) AND (83) WITH NEW ONES.
8. ASSEMBLE AGAIN IN REVERSE ORDER, REPLACING ALL METALLIC SEALS (72) AND (74) WITH NEW ONES.
9. ALL NECESSARY SEALS ARE INLCUDED IN THE AVAILABLE KIT L79833598.

### CLEANING OR REPLACING LOWER END VALVES

1. BY DISASSEMBLING THE LOWER END AS DESCRIBED PREVIOUSLY, THE FLUID VALVES CAN BE EASILY ACCESSED.
  2. LOWER VALVE: PARTS FROM (86) TO (92). KIT L79833599.
  3. UPPER VALVE: PARTS FROM (76) TO (80). KIT L79833411.
- NOTE:** TO UNSCREW THE UPPER VALVE (80), SECURE IT IN A VISE AND UNSCREW THE ROD (75) BY GRABBING IT IN THE PIN (70) AREA IN ORDER TO AVOID DAMAGING THE QUALITY OF THE SURFACE INTENDED FOR SEALING.

### SPARE PARTS

REPAIR KITS		
PART NUMBER	DESCRIPTION	INDIVIDUAL POSITION
L79833598	LOWER SEAL KIT	52, 2X54, 55, 57, 72, 4X74, 2X82, 83, 88, 89, 90
L79833599	LOWER VALVE KIT	86, 87, 88, 89, 90, 91, 92
L79833411	UPPER VALVE KIT	76, 77, 78, 79, 80
L79833412	AIR MOTOR SEAL KIT	6, 7, 2X8, 10, 44
L79833413	EXHAUST MUFFLER KIT	16, 17, 4X24, 25, 4X26, 4X27, 28, 29, 2X30, 31
L79833414	SPOOL + SEAL KIT	5X18, 19, 20
L794140-058	CAM-LOCK 3" M (L791450-007)	

**PARTS LIST**

<b>POSITION</b>	<b>DESCRIPTION</b>	<b>CANT.</b>
1	EYE BOLT	1
2	SCREW	4
3	TOP COVER	1
4	PILOT SLEEVE	1
5	SENSOR NUT	1
6	O-RING	1
7	BACK-UP RING	1
8	O-RING	3
9	PILOT VALVE	1
10	O-RING	1
11	1/2" NTPF ADAPTER	1
12	BONDED SEAL	1
13	AIR MOTOR BODY	1
14	O-RING	3
15	AIR DISTRIBUTING SLEEVE	1
16	O-RING	2
17	PLUG	1
18	DISTRIBUTOR SEAL	5
19	DISTRIBUTOR SPOOL	1
20	O-RING	1
21	SPOOL BUMPER	1
22	O-RING	1
23	DISTRIBUTOR STOPPER	1
24	SCREW	8
25	EXHAUST MUFFLER BODY	1
26	SPRING WASHER	4
27	SCREW	4
28	EXHAUST MUFFLER DEFLECTOR	1
29	EXHAUST MUFFLER STOPPER	1
30	SIDE FELT	2
31	CENTRAL FELT	1
32	MOTOR WASHER	1
33	O-RING	4

**PARTS LIST (CONTINUED)**

<b>POSITION</b>	<b>DESCRIPTION</b>	<b>CANT.</b>
34	O-RING	1
35	MOTOR SEAL	1
36	UPPER BRIDLE	1
37	SCREW	5
38	O-RING	2
39	O-RING	2
40	SENSOR ROD	1
41	AIR PISTON BUMPER	1
42	AIR PISTON NUT	1
43	O-RING	1
44	O-RING	1
45	AIR PISTON	1
46	O-RING	1
47	AIR PISTON WASHER	1
48	SENSOR SPOKE	1
49	AIR MOTOR ROD	1
50	AIR MOTOR CYLINDER	1
51	SCRAPER NUT	1
52	SCRAPER	1
53	SCRAPER WASHER	1
54	HP SEAL	2
55	SLIDE RING	1
56	HP SEALS GASKET	1
57	O-RING	1
58	LOWER BRIDLE	1
59	HANDLE	2
60	SCREW	4
61	WASHER	4
62	SPRING WASHER	4
63	SCREW	4
64	O-RING	1
65	SCREW	1
66	PLUG	1
67	BONDED SEAL	1
68	SCREW	4
69	PUMP BODY	1

**PARTS LIST**

<b>POSITION</b>	<b>DESCRIPTION</b>	<b>CANT.</b>
70	ELASTIC PIN	3
71	LONG CONNECTING ROD	1
71	SHORT CONNECTING ROD	1
71	BULK CONNECTING ROD	1
72	METALLIC SEAL	1
73	LONG UPPER TUBE	1
73	SHORT UPPER TUBE	1
73	BULK UPPER TUBE	1
74	METALLIC SEAL	4
75	HP PISTON	1
76	KEY	1
77	BALL	1
78	SPACER	1
79	METALLIC SEAL	1
80	UPPER VALVE BODY	1
81	BARREL	1
82	SLIDE RING	2
83	HP SEAL	1
84	CENTRAL TUBE	1
85	PRIMER ROD	1
86	VALVE STOP	1
87	V-CLIP	1
88	VALVE WASHER	1
89	SLIDE RING	1
90	HP SEAL	1
91	LOWER VALVE BODY	1
92	LOWER VALVE BASE	1
93	SHOVEL	1
94	NUT	1
95	LOWER TUBE	1
96	1/2" BSPF ADAPTER	1
97	O-RING	1
98	3" CAMLOCK MALE ADAPTOR	1
99	SPRING WASHER	4
100	SCREW	4

PARTS DRAWING

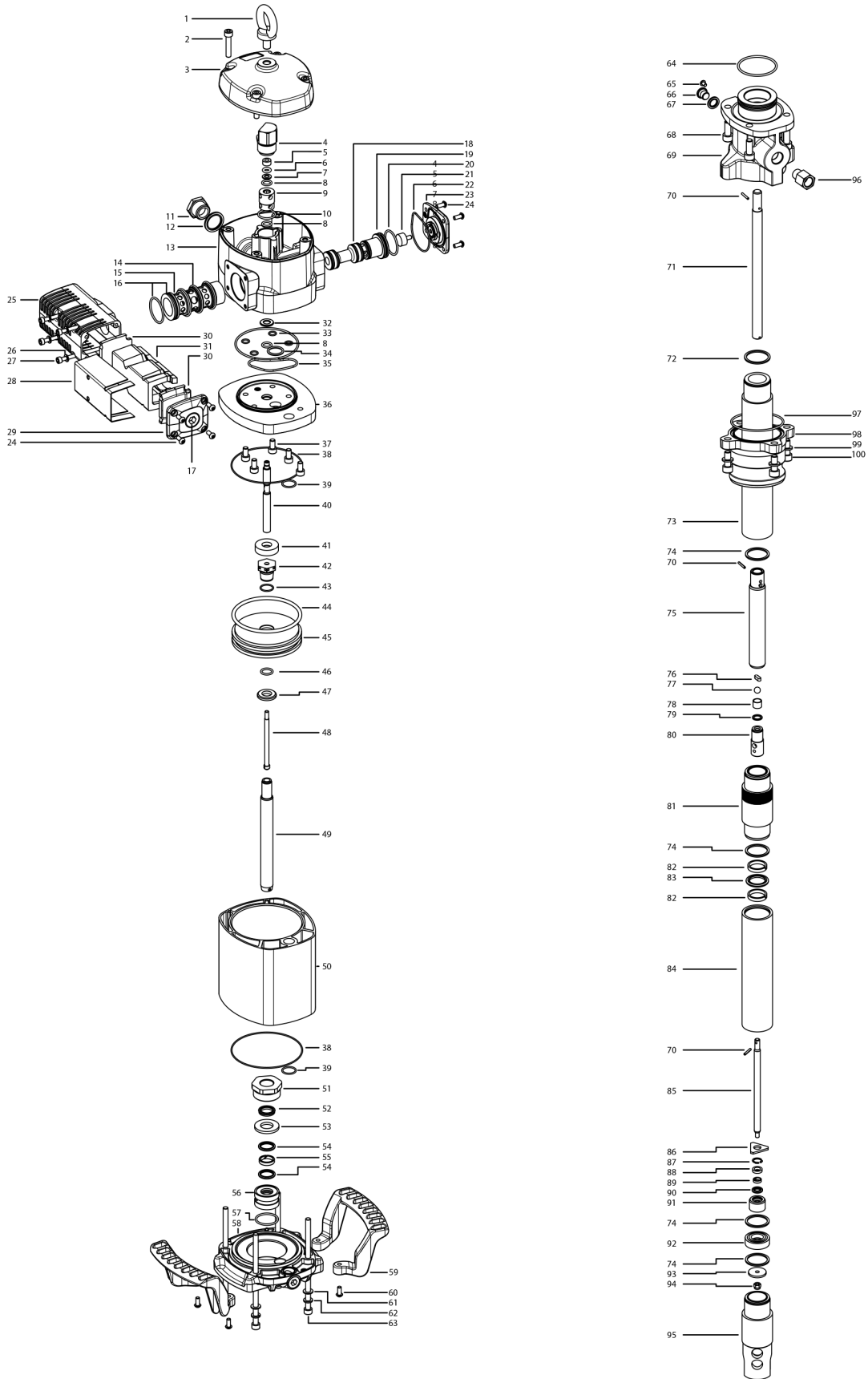

**TECHNICAL DATA**  
**L791450-005 / L791450-006 / L791450-007**

MAXIMUM AIR PRESSURE	100 PSI (7 BAR)
MINIMUM AIR PRESSURE	29 PSI (2 BAR)
MAXIMUM DELIVERY	24 LB/MIN @ 100 PSI (7.5 KG/MIN @ 7 BAR)
AIR INLET THREAD	1/2" NPT
FLUID OUTLET THREAD	1/2" NPT
AIR PISTON DIAMETER	4.5" (115MM)
STROKE	4" (100MM)
WEIGHT	55LB (25KG)
WETTED MATERIALS	CAST IRON, STEEL, HARD CHROMED STEEL, UHMW PE, NBR, PTFE

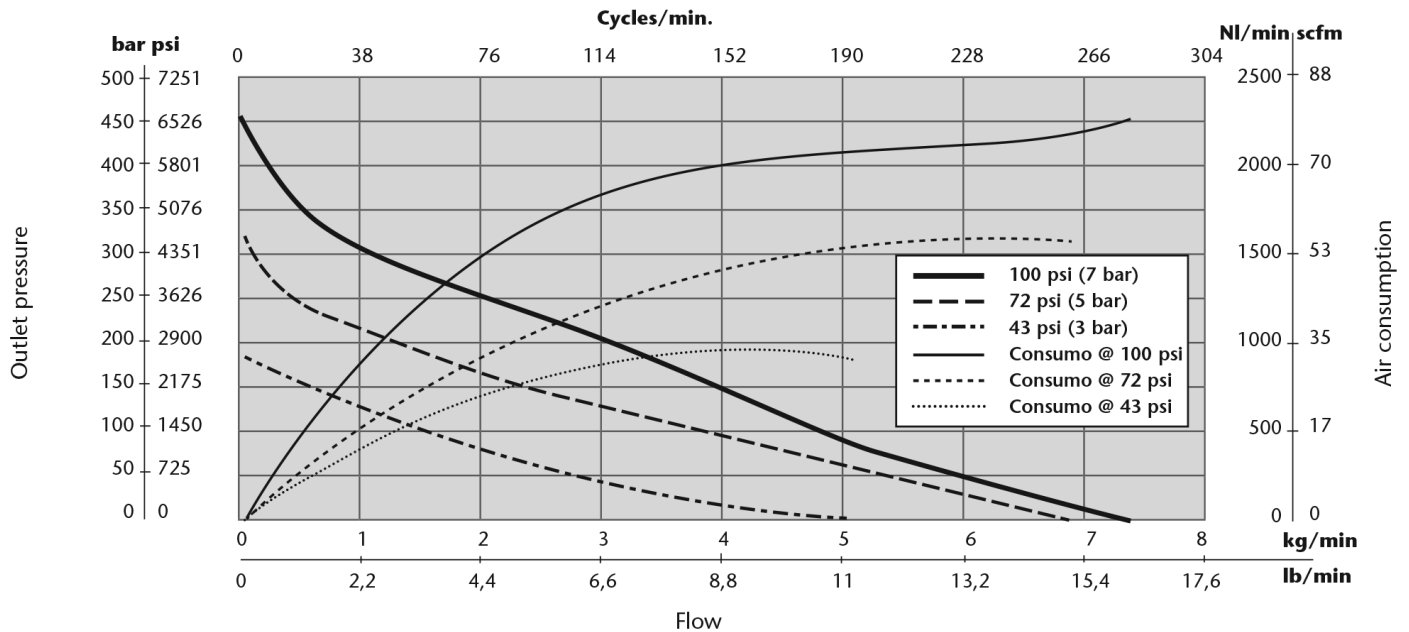



**DIMENSIONS**

4xM10 holes  
 Ø112 mm hole pattern

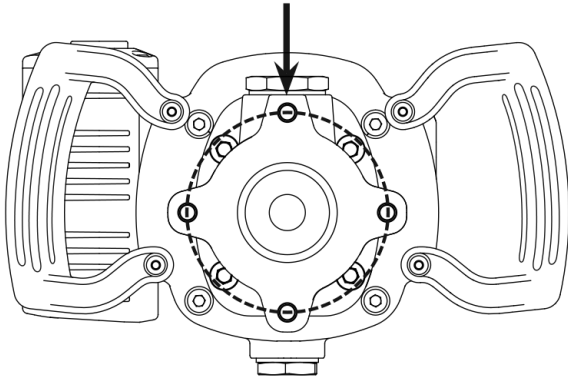

MODEL	A (INCHES/ MM)	B (INCHES/ MM)	C (INCHES/ MM)	WEIGHT
L791450-005	33" / 855MM	53" / 1357MM	-	55LB (25KG)
L791450-006	25" / 650MM	45" / 1152MM	-	50LB (23KG)
L791450-007	19" / 490MM	39" / 992MM	16" / 410MM	46LB (21KG)

C, D	E
1/2" NPTF	1/4" BSPF

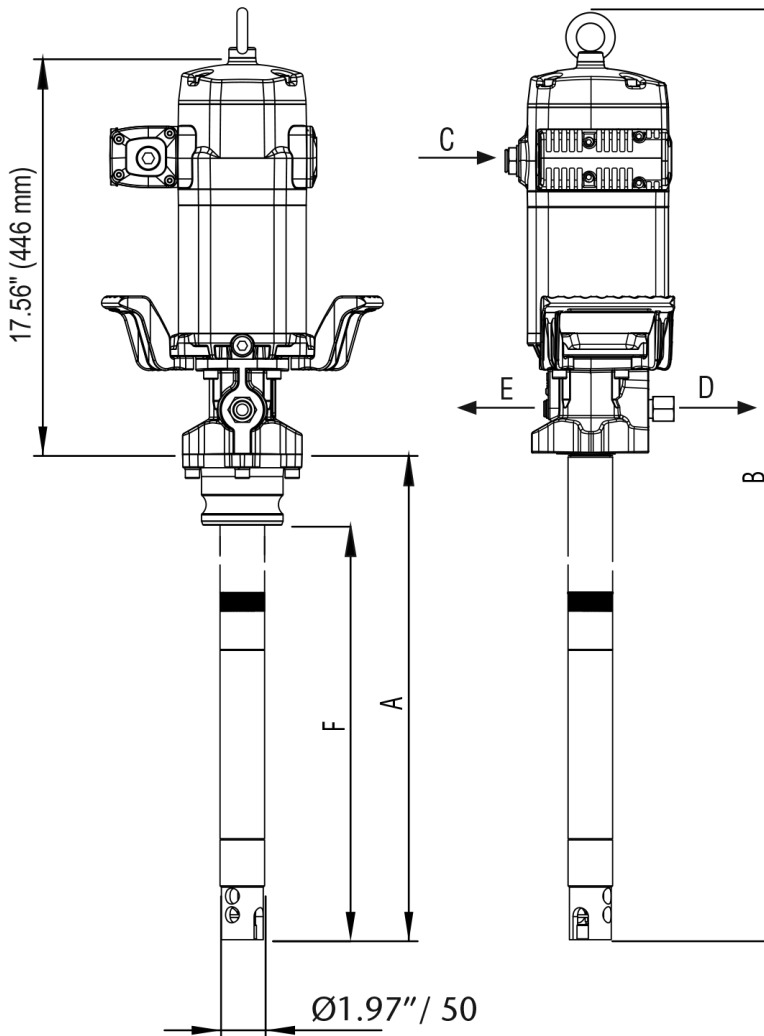



**Customer Service (877-452-0157)**

- ◆ Order status & order entry
- ◆ Pricing inquiries
- ◆ Part number look-ups
- ◆ Product availability information
- ◆ Shipment assistance
- ◆ All other general inquires

**www.lubricationsscintifics.com**

- ◆ Product information, specifications, literature
- ◆ Locate sales reps and distributors
- ◆ Operator & Repair manuals
- ◆ Distributer Information
- ◆ Place orders and check current pricing
- ◆ Product Pricing



LUBRICATION SCIENTIFICS, LLC

17651 ARMSTRONG AVE.

IRVINE, CA 92614

UNITED STATES OF AMERICA

TOLL FREE TEL: (877) 452-0157, LOCAL TEL: (714) 557-0664, FAX: (714) 546-4564

**WWW.LUBRICATIONSCIENTIFICS.COM**